

# CITY OF FARMERSVILLE, TEXAS



## THOROUGHFARE STANDARDS DESIGN MANUAL

*Adopted September 12, 2006  
By Ordinance #2006-46  
Amended June 12, 2007  
By Ordinance #2007-23*

# TABLE OF CONTENTS

I.	General Requirements.....	1
II.	Street Design Standards.....	3
III.	Median and Left Turn Lane Design Standards.....	7
IV.	Alley Design Standards.....	11
V.	Driveway Design Standards.....	12
VI.	Sidewalk and Location Design Standards.....	19
VII.	Public Right-of-Way Visibility.....	21
VIII.	Off Street Requirements.....	27
IX.	Rural Subdivision Requirements.....	29

# **SECTION I**

## **GENERAL REQUIREMENTS**

### **A. INTRODUCTION**

The “Thoroughfare Design Standards” are intended to implement the provisions of the Subdivision Ordinance and to provide for the orderly, safe, healthy and uniform development of the area within the corporate city limits and in the extraterritorial jurisdiction (ETJ) surrounding the City of Farmersville.

The City of Farmersville “Standard Construction Details”, “Special Provisions” and the North Central Texas Council of Governments (NCTCOG) “Standard Specifications for Public Works Construction” are considered supplemental and are part of the Thoroughfare Design Standards. The Thoroughfare Design Standards are to be considered as the minimum requirements for engineering design. Adherence to the requirements of these standards and/or approval by the City of Farmersville or its authorized representatives in no way relieves the developer or his engineer for adequacy of design or for the completeness of the plans and specifications or the suitability of the completed facilities. Specific projects may require more stringent design standards. The City of Farmersville may determine that design requirements other than those included in these standards are necessary and will inform the developer of such requirements before the final engineering review.

The developer shall notify the City of Farmersville, in writing, of any known deviations from the requirements set for in the standards for thoroughfare design, construction details, or specifications.

### **B. THOROUGHFARE DESIGN STANDARDS**

The Thoroughfare Design Standards are to be considered as the minimum requirements for engineering design. It is not intended that these standards cover all aspects of paving construction for any given development. The developer shall provide proper engineering design for all facilities not covered by these standards in accordance with good engineering practice and shall utilize first class workmanship and materials in all construction.

### **C. SPECIAL PROVISIONS AND STANDARD SPECIFICATIONS**

The City of Farmersville has adopted the most recent version of the NCTCOG Standard Specifications for Public Works Construction together with the Special Provisions to the Standard Specifications. These documents set forth the minimum requirements for materials and workmanship for public works construction.

**D. STANDARD CONSTRUCTION DETAILS**

The City of Farmersville has adopted a set of standard construction details in order to promote uniformity of development and to facilitate maintenance of various public works facilities. The standard construction details are to be considered as the minimum requirements for materials and workmanship for public works construction.

**E. INSPECTION OF CONSTRUCTION BY CITY PERSONNEL**

Inspection of construction activities shall be conducted by staff of the City of Farmersville under direction of the City Engineer or authorized representative. The City inspector shall observe and check the construction in sufficient detail to satisfy himself that the work is proceeding in general conformance with the standards and specifications for the project, but he will not be a guarantor of the Contractor's performance. The City will not accept any development until City staff has approved all construction. The developer shall be responsible for any additional expense to the City for inspection that is necessary after normal business hours, or when the improvements will be privately owned. The City will establish the rate for compensation and other expenses.

The developer will be responsible for furnishing the original reproducible engineering drawings corrected to show any revised construction conditions to the City before any improvements will be accepted. All public works improvements must be accepted by the City before any City Building permits will be issued.

## SECTION II

### STREET DESIGN STANDARDS

#### A. DEFINITIONS

<b>TABLE I</b>				
<b>Type</b>	<b>R-O-W</b>	<b>Pavement (Face to Face)</b>	<b>Median (Face to Face)</b>	<b>Parkway Width</b>
Major Thoroughfare (Type B)	120'	6/12' (72')	22'	13'
Secondary Thoroughfare (Type C)	100'	4/12' (48')	24'	14'
Collector (Type D)	65'	38'	None	13.5'
Residential Street (Type E)	50'	31'	None	9.5'
Estate Residential (Type E-1)	60'	32'*	None	14'

\* - Pavement dimension for Estate Residential is Edge to Edge of Shoulder.

Above defined by the City of Farmersville, Texas, Comprehensive Plan and most recent Major Thoroughfare Plan.

#### B. MINIMUM HORIZONTAL DESIGN RADIUS

Minimum Centerline Radius is defined by the design speed of the respective street. The design speed of each street In the City of Farmersville, as defined by the Thoroughfare Plan, can be determined from Table 2.

**TABLE 2**  
**DESIGN SPEED OF EACH TYPE OF STREET**

<u>Street Type</u>	<u>Design Speed</u>
Residential (Type E & E-1) .....	25
Collector (Type D) .....	30
Secondary Thoroughfare (Type C) .....	40

The minimum acceptable horizontal centerline radius, for each respective street's design speed, is shown in Table 3. The cross slope is assumed to be 1/4" per foot from the inside toward the outside.

**TABLE 3**  
**MINIMUM HORIZONTAL CENTERLINE RADIUS**

<u>Y</u> (mph)	<u>f</u>	<u>e</u> (ft/ft)	<u>(e + f)</u>	<u>R</u> (Calculated) (ft)	<u>R</u> (Rounded for Design) (ft)
25	0.170	-0.0208	0.1492	279.27	280
30	0.160	-0.0208	0.1392	431.03	440
35	0.150	-0.0208	0.1292	632.09	640
40	0.145	-0.0208	0.1242	858.83	860
45	0.142	-0.0208	0.1212	1,113.86	1,120
50	0.140	-0.0208	0.1192	1,398.21	1,400
55	0.130	-0.0208	0.1092	1,846.76	1,850
60	0.120	-0.0208	0.0992	2,419.35	2,420

(AASHTO P 177)

Minimum centerline design radius for residential streets shall be 280-feet for curves with a length over 125 feet long.

**C. MINIMUM VERTICAL ALIGNMENT**

Vertical Alignment is a function of Stopping Sight Distance (SSD), which is given by:

$$SSD = 1.47PV + \frac{V^2}{30(f + g)}$$

(Transportation and Traffic Engineering Handbook, Second Edition, Page 590)

Stopping Sight Distances are calculated for g = 0, rates of vertical curvature are derived from AASHTO Page 307, 312 and 316 and used (K) to determine crest curve lengths per Table 4.

The maximum grade for residential streets is 10% unless otherwise approved by the City where natural topography is such as to require steeper grades. The maximum grade for all other streets shall be 7.50%. The minimum grade for all streets is 0.50%.

# TABLE 4

**MINIMUM ACCEPTABLE CREST CURVE GIVEN SPEED AND  
DIFFERENCE IN GRADE OF ROAD**

<b>S</b>		<b>K</b>	<b>L-KA</b>									
<b>MPH</b>	<b>Ft.</b>		<b>A-1</b>	<b>A-2</b>	<b>A-3</b>	<b>A-4</b>	<b>A-5</b>	<b>A-6</b>	<b>A-7</b>	<b>A-8</b>	<b>A-9</b>	<b>A-10</b>
30	200	30	100	100	100	120	150	180	210	240	270	300
35	250	50	100	100	150	200	250	300	350	400	450	500
40	325	80	100	160	240	320	400	480	560	640	720	800
45	400	120	120	240	360	480	600	720	840	960	1080	1200
50	475	160	160	320	480	640	800	960	1120	1280	1440	1600
55	550	220	220	440	660	880	1100	1320	1540	1760	1980	2200
60	650	310	310	620	930	1240	1550	1860	2170	2480	2790	3100

# TABLE 5

**MINIMUM ACCEPTABLE SAG CREST CURVE GIVEN SPEED AND  
DIFFERENCE IN GRADE OF ROAD**

<b>S</b>		<b>K</b>	<b>L-KA</b>									
<b>MPH</b>	<b>Ft.</b>		<b>A-1</b>	<b>A-2</b>	<b>A-3</b>	<b>A-4</b>	<b>A-5</b>	<b>A-6</b>	<b>A-7</b>	<b>A-8</b>	<b>A-9</b>	<b>A-10</b>
30	200	40	100	100	120	160	200	240	280	320	360	400
35	250	50	100	100	150	200	250	300	350	400	450	500
40	325	70	100	140	210	280	350	420	490	560	630	700
45	400	90	100	180	270	360	450	540	630	720	810	900
50	475	110	110	220	330	440	550	660	770	880	990	1100
55	550	130	130	260	390	520	650	780	910	1040	1170	1300
60	650	160	160	320	480	640	800	960	1120	1280	1440	1600

**D. INTERSECTION CURB RADII**

The radius shall be thirty (30) feet at the intersection of all intersecting streets unless otherwise approved by the City Engineer or Authorized Representative.

See Detail, page 10.

**Note:** At many intersections, the curb radius encroaches on the right-of-way so as to not provide sufficient room for sidewalks, utilities, etc. within the parkway. Therefore, right-of-way will be dedicated at the intersection of all streets such that a minimum of nine and one-half (9.5) feet of parkway shall be maintained from the back of the curb along the curb's radius.

**E. RESIDENTIAL FRONTAGE**

Residential houses shall not front a thoroughfare unless parallel access roads are provided. Minimum distances between adjacent curbs or the thoroughfare and the access road shall be twenty (20) feet.

**F. STATE DESIGNATED ROADS**

All such roads within the City of Farmersville will conform to State Design Standards unless otherwise directed by the City Engineer.

## SECTION III

### MEDIAN AND LEFT TURN LANE DESIGN STANDARDS

**A. WIDTH OF MEDIAN**

Median widths vary from a minimum of 4' (with left turn lanes) to a maximum of 24' (see Table 1).

**B. REQUIRED MEDIAN OPENING AND LEFT-TURN LANE**

Median openings on divided thoroughfares shall be provided at all dedicated street intersections and at private drives where they conform to the City's spacing requirements. A left turn lane for the proposed drive or street shall accompany the median opening.

**C. COST OF MEDIAN OPENINGS AND LEFT-TURN LANES**

Median openings and left-turn lanes constructed to serve private drives and new roads shall be paved to City standards, inspected by City Inspectors, and paid for by owners served by the median openings and left-turn lanes. The City shall be responsible for, and pay the costs of, the paving of median openings and left-turn lanes, constructed to serve existing dedicated streets, and those that exist for drives, when a part of the Capital Improvement widening program is undertaken by the City on an existing public street.

**D. MINIMUM LEFT-TURN STORAGE, TRANSITION LENGTH, AND MEDIAN OPENING WIDTH, LOCATION, AND SPACING REQUIREMENTS**

(1) Left Turn Storage

All left-turn storage areas shall be ten (10) feet wide with minimum storage requirements for left-turn lanes as in Table 6.

**TABLE 6**

**MINIMUM LEFT TURN STORAGE REQUIREMENTS**

<u>Intersecting Thoroughfares</u>	<u>Minimum Storage</u>
Major with Major .....	150 feet
Major with Secondary .....	100 feet
Major with Residential .....	60 feet
Major with Private Drive .....	60 feet
Secondary with Major .....	100 feet
Secondary with Residential .....	60 feet
Secondary with Private Drive .....	60 feet

**Note:** Storage requirements listed herein are absolute minimums. Storage requirements may increase based upon actual and projected traffic demands.

(2) Transition Length

The transition curves used in left-turn lanes shall be two 250-foot radius reverse curves, which will require a total transition length of 100-feet.

(3) Median Openings

- a) Median openings at Intersections shall be from right-of-way to right-of-way or the intersecting street.
- b) The minimum width of mid-block median openings shall not be less than sixty (60) feet. See Detail, page 9.

(4) Medians Where No Left-Turn Pocket is Needed

- a) If left-turn storage is provided in only one direction, (i.e., a drive cannot be installed for the other direction), the minimum length of median must be the required left-turn storage and transition length, plus 30-feet of median length beyond the end of the transition.
- b) If the left turn storage is not required in either direction, but the median is simply a spacer between two median openings, the minimum length of the spacer must be 50-feet. See Detail, page 10.

(5) Medians into Developments on Public Streets

Medians installed on undivided streets at entrances to subdivisions for aesthetic or any other purpose will be a minimum of 4-feet wide and 100-feet long.

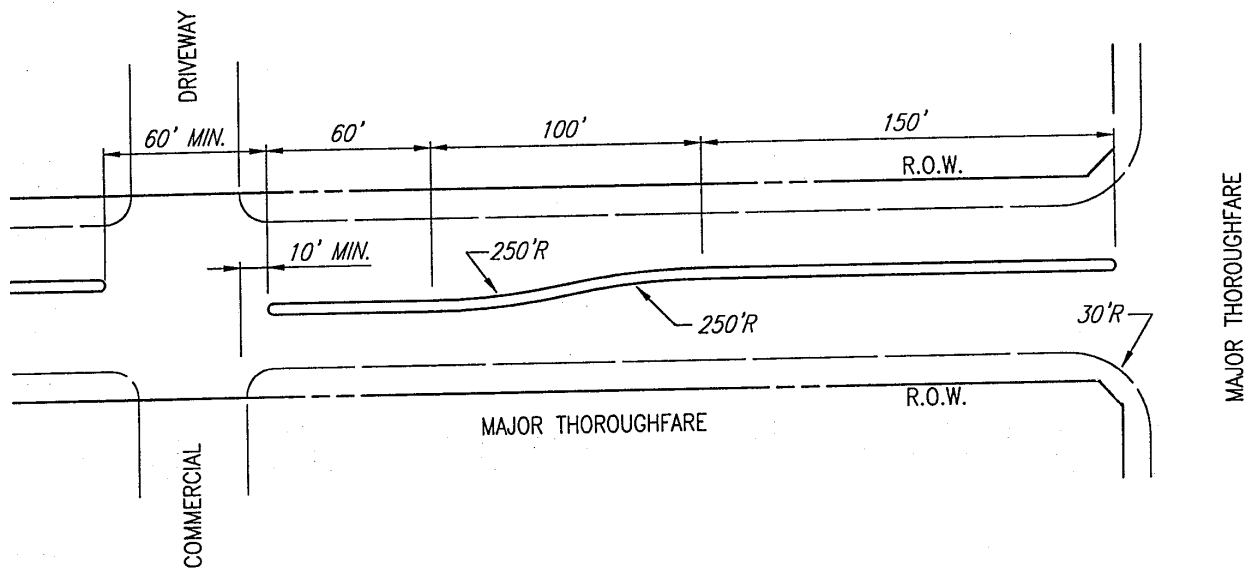

TYPICAL MEDIAN OPENING SPACING  
MAJOR THOROUGHFARE

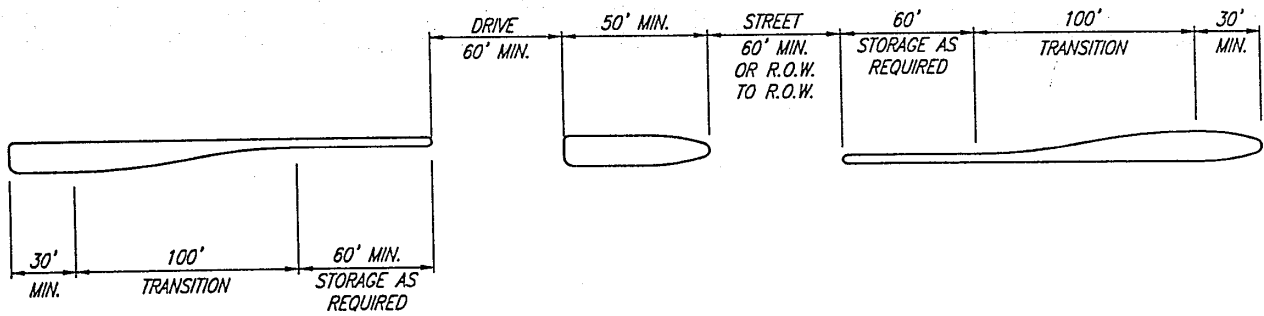

TYPICAL MEDIAN DIMENSIONS WITHOUT  
BACK TO BACK LEFT TURN POCKETS

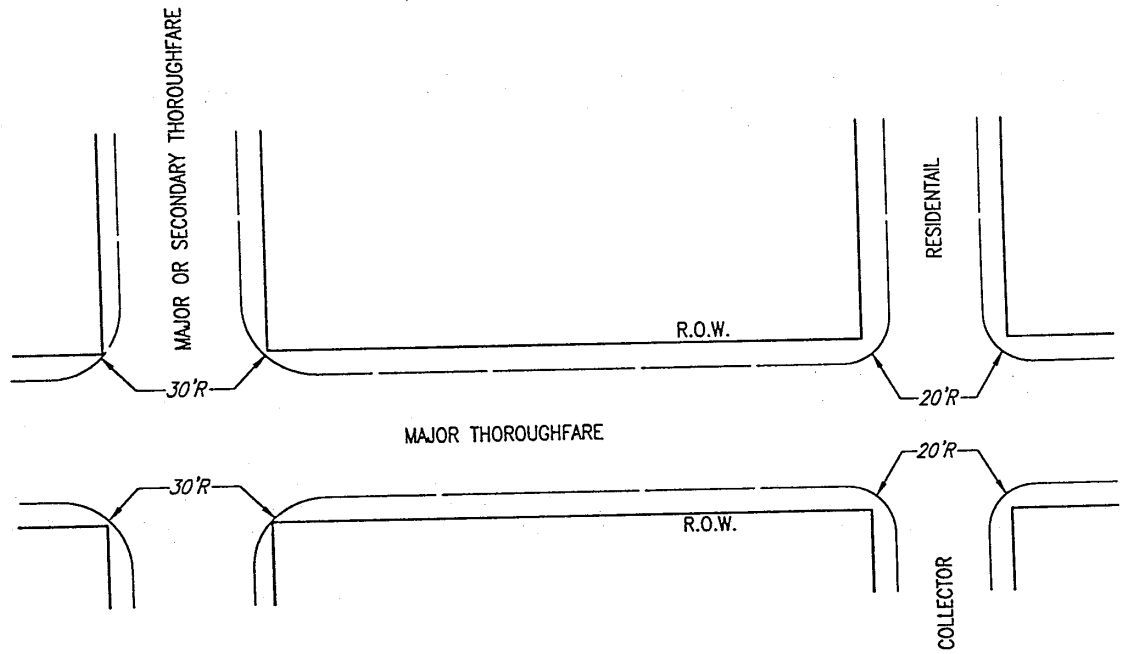

CURB RADII AT INTERSECTION

## **SECTION IV**

### **ALLEY DESIGN STANDARDS**

#### **A. ALLEY REQUIREMENTS FOR DEVELOPMENTS**

Alleys shall be constructed in accordance with City of Farmersville Subdivision Ordinance. Alleys shall be provided in all residential areas and shall be paved with concrete in accordance with the City's Standard Construction Details. The City Council may waive the residential alley requirement upon determination of the Council that such a waiver is in the best interest of the City. Alleys may be required in commercial and industrial developments. The City may waive the commercial and industrial alley requirement upon determination of the Council, if in its opinion adequate provisions are made for service access such as off-street loading, unloading and parking consistent with the uses proposed.

#### **B. ALLEY INTERSECTIONS**

Alleys shall not intersect major or secondary thoroughfares with medians. Alleys which run parallel to and share a common right-of-way line with a major thoroughfare shall turn away from the major street not less than one subdivision lot width or a minimum of 50-feet (whichever is greater) from the cross street intersection.

#### **C. ALLEY WIDTHS**

The minimum alley right-of-way width shall be twenty (20) feet with a minimum 12-foot paved width. Dead-end alleys shall not be permitted without special permission from the City Engineer or Authorized Representative. The geometry of alley construction shall conform to the Standard Construction Details.

#### **D. ALLEY RADIUS**

Alley radii at street intersections in residential developments shall not be less than 10-feet.

Alley radii at street intersections in commercial and residential developments shall not be less than 30-feet unless approved by the City Engineer or Authorized Representative.

## SECTION V

# DRIVEWAY DESIGN STANDARDS

### A. DEFINITION OF DRIVEWAY TYPES

For purposes of interpreting the provisions of these Rules and Regulations, the following definitions shall apply:

- (1) A "residential" driveway provides access to a single-family residence, to a duplex, or to a multi-family building containing five or fewer dwelling units. These drives shall intersect residential and commercial roadways only. All access to residential property abutting all other thoroughfares shall be off the alley or a service road.
- (2) A "commercial" driveway provides access to an office, retail or institutional building, or to a multiple-family building having more than five dwelling units. It is anticipated that such buildings will have incidental truck service. Commercial drives shall access to Major or Secondary Thoroughfares only.
- (3) An "industrial" driveway serves substantial numbers of truck movements to and from loading docks of an Industrial facility, warehouse, or truck terminal. A central retail development, such as a community or regional shopping center, may have one or more driveways specially designed, signed, and located to provide access for trucks and such driveways shall be considered industrial driveways. Industrial plant driveways whose principle function is to serve administrative or employee parking lots shall be considered commercial driveways. Industrial drives shall access to Major or Secondary Thoroughfares only.

**Note:** Two-way driveways shall always be designed to intersect the street at a 90° angle. One-way driveways may be designed to intersect a street at a 45° angle.

### B. *DRIVEWAY WIDTH*

As the term is used here, the width of a driveway refers to the width of pavement at the property line.

- (1) Residential driveways onto streets shall have a minimum width of 12-feet and a maximum width of 24-feet. Joint access residential drives shall have no less than nine (9) feet on any property. See Detail (a), page 15.

- (2) Commercial/Industrial. Two-way operation: See Detail (b), page 15.
  - a) Commercial driveways shall have a minimum width of twenty-four (24) feet and a maximum width of 30-feet.
  - b) Industrial driveways shall have a minimum width of 30-feet and a maximum width of 40-feet. Joint access commercial/industrial drives shall have no less than Ten (10) feet on any property, with the full drive width and access pavement to the property built for the development at the same time.
- (3) Commercial/Industrial - One way operation:
  - a) 90-degree drives shall have a width of 18-feet for ingress and 22-feet for egress, with the separation median width being a minimum of 4-feet and a maximum of 10-feet. See Detail (c), page 16.
  - b) 45-degree drives shall have a width of 18-feet for ingress and 16-feet for egress, with the separation median width being a minimum of 4-feet and a maximum of 10-feet. Joint access commercial/industrial drives shall have no less than 10-feet on any property, with the full drive width and access pavement to the property built for the development at the same time. See Detail (d), page 16.

### C. **DRIVEWAY RADIUS**

All driveways intersecting dedicated streets shall be built with a circular curb radius connecting the 6-inch raised curb of the roadway to the design width pavement of the driveway. All driveways shall provide for barrier free access. Driveway radii shall fall entirely within the subject property so as to begin at the street curb, at the extension of the property line.

- (1) 90-Degree Intersection (See Detail, page 15)
  - a) The curb radii for a residential drive shall be a minimum of 5-feet and a maximum of 10-feet.
  - b) The curb radii for commercial and industrial drives shall be 30-feet unless otherwise approved by the City.
- (2) 45-Degree Intersection

The curb radii shall be 5-feet for the outside of the drive and 2½-feet for the median. See Detail, page 16.

In order that the definition of the location of the edge of pavement for the thoroughfare may be maintained, driveway radii shall always be designed to become tangent to the street curb line. All commercial and industrial drives will have an unbroken curb length of not less than 20-feet

from the right-of-way, or 30-feet from the roadway curb extending into the site on each side of the drive.

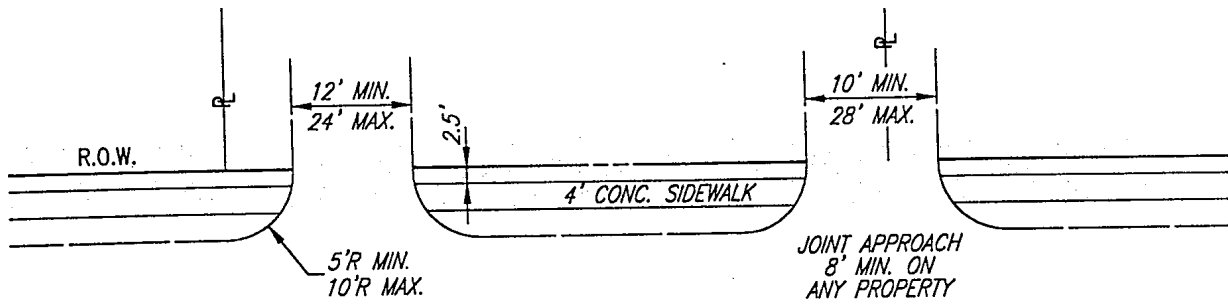

(a) DRIVEWAYS WIDTH, RADIUS, SPACING

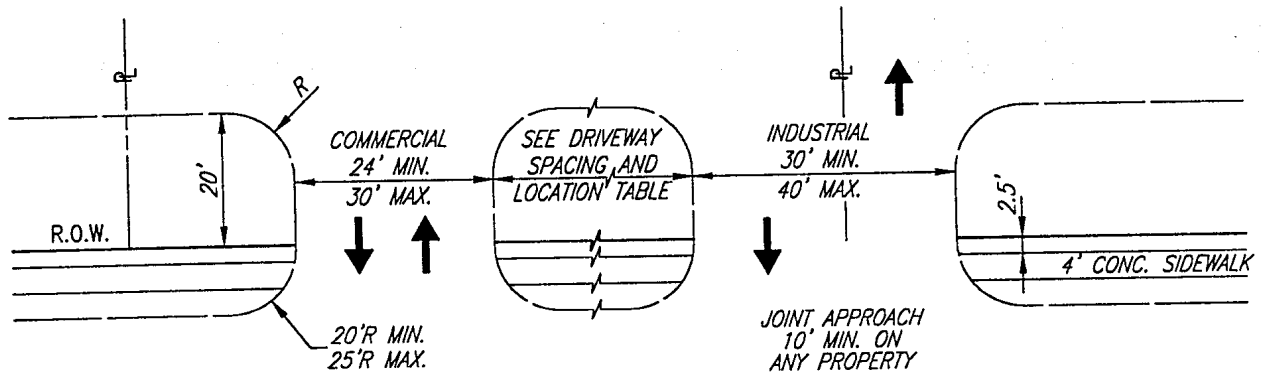

(b) DRIVEWAYS WIDTH, RADIUS, SPACING

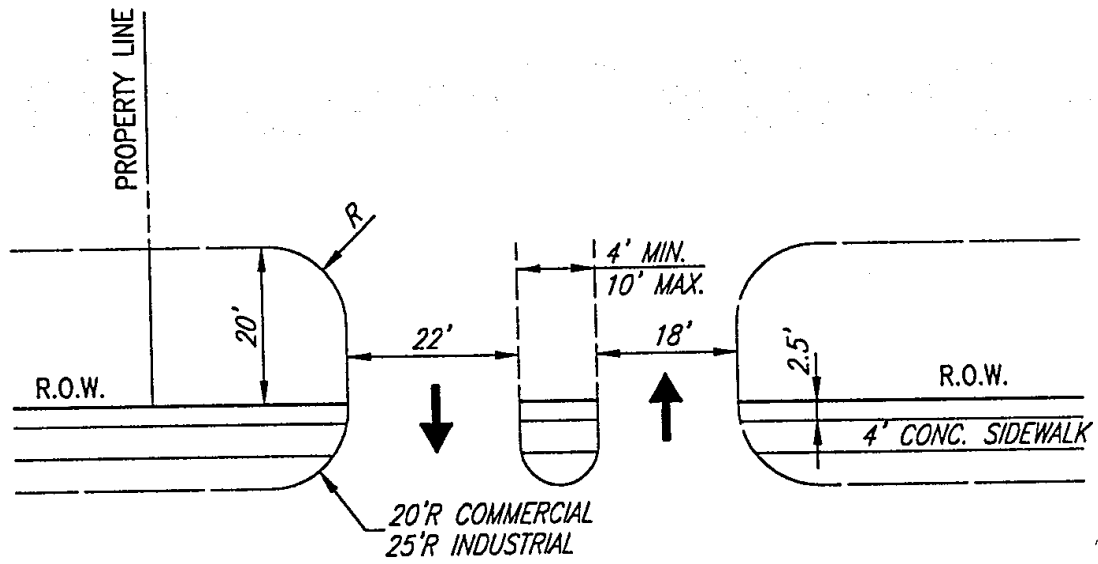

(c) DRIVEWAYS WIDTH, RADIUS, SPACING

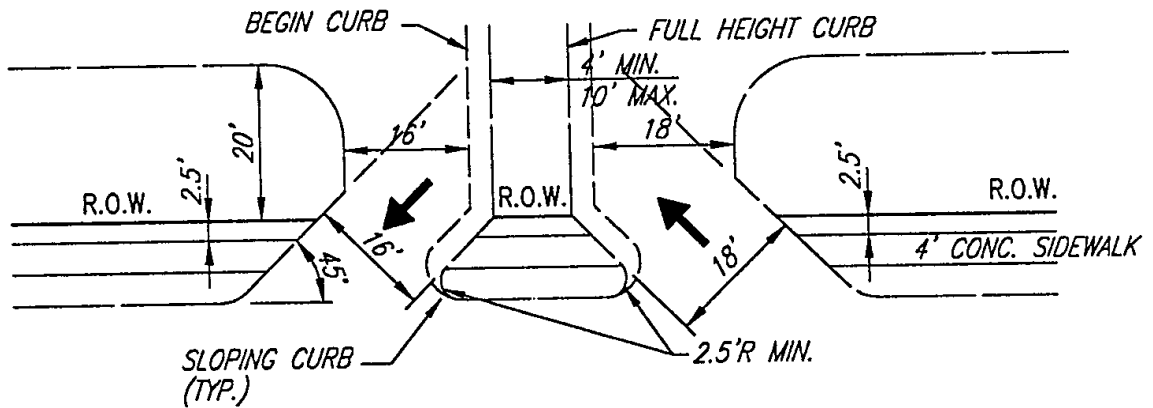

(d) DRIVEWAYS WIDTH, RADIUS, SPACING

**D. DRIVEWAY SPACING AND LOCATION IN RELATION TO OTHER DRIVES**

(1) Residential

Driveway approaches on a tract of land devoted to one use shall not occupy more than 70% of the frontage abutting the roadway. No more than two driveway approaches shall be permitted on any parcel of property on each street.

(2) Commercial and Industrial

The spacing and location of driveways shall be related to both existing adjacent driveways and those shown on approved development plans. The spacing between driveways shall depend upon the design speed of the street as shown Table 7. Driveways shall not be permitted in the transition area of a deceleration lane or a right turn lane.

**TABLE 7**

**DRIVEWAY SPACING IN RELATION TO OTHER DRIVES GIVEN THE DESIGN SPEED OF THE STREET**

<u>Design Speed (MPH)</u>	<u>Driveway Spacing (Ft.)</u>
25 .....	65
30 .....	90
35 .....	100
40 .....	120
45 .....	150
50 .....	200

The minimum spacing shall not be more than 10-feet less than shown above. Spacing between driveways will be measured along the property line from the edge of one driveway to the closest edge of the next driveway and not from centerline to centerline.

**E. DRIVEWAY SPACING IN RELATION TO A CROSS STREET**

(1) 90 Degree Intersection - Drive to Road

- a) Driveways that intersect at 90 degrees to a residential or "secondary street" shall be located a minimum of the drive radius from a residential street's end of curb radius.
- b) A driveway that Intersects at 90 degrees to a residential or secondary street shall be located a minimum of thirty (30) feet from a secondary or major street's end of curb radius. (see Detail (a), page 19)

- c) A driveway that intersects at 90 degrees to a major street shall be located a minimum of 100-feet from any intersecting street's right-of-way or from the end of any intersecting street's curb radius as determined by the City Engineer. If the property length, along the street, is such that both the drive and the drive's curb radius cannot be totally within the proposed development, the drive will be situated so as to be a joint access drive. (see Detail (b), page 19)

(2) 45 degree Intersection - Drive to Road

- a) If one-way angle drives are used, the radius for the driveway on a residential or secondary may not begin less than 35-feet from an intersecting street's end of curb radius.
- b) On a major street the drive shall be located a minimum of 100-feet from any intersecting street's right-of-way. If a property length, along the street, is such that both the drive and drive's curb radius cannot be totally within the proposed development, the drive will be situated so as to be a joint access drive. (see Detail (c), page 19)

A summary of driveway widths, radii, and angle requirements are given in Table 8.

TABLE 8

*SUMMARY OF DRIVE REQUIREMENTS*

	Residential	Commercial	One-Way		Industrial
			In	Out	
Width (ft)					
Minimum	12	20			30
One-way (only)					
90°			18	22	
45°			18	16	
Maximum	24	30			40
Curb Radius (ft)					
45° (one-way)	5	10	10	10	10
90°	5 – 10	30	Same	Same	30
Intersection					
Angles (deg.)	90°	90°	90°	90°	90°
	45°	45°	45°	45°	45°

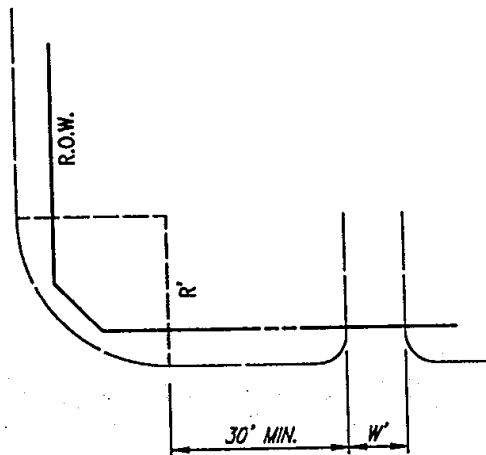

(a) DRIVE INTERSECTING A RESIDENTIAL OR SECONDARY

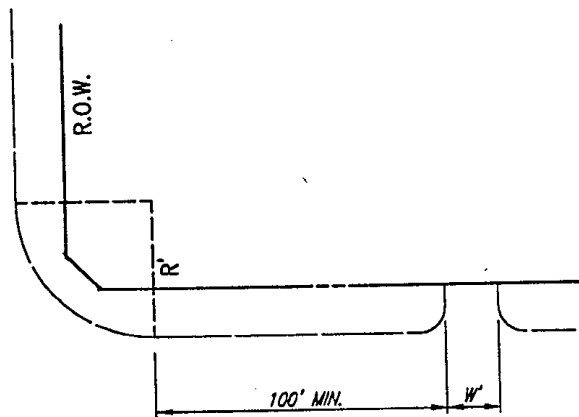

(b) 90° DRIVE INTERSECTING A MAJOR

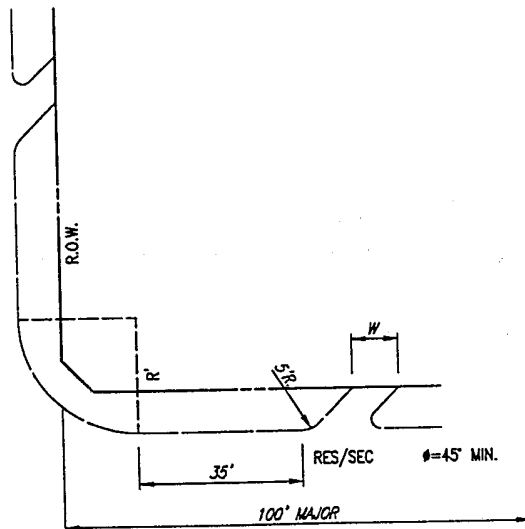

**(c) ANGLE DRIVE**

## SECTION VI

### SIDEWALK AND LOCATION DESIGN STANDARDS

#### A. DEFINITION OF SIDEWALK

A sidewalk is defined as that paved area in a roadway right-of-way between the curb lines or the edge of pavement of the roadway and the adjacent property lines for the use of pedestrians. The maximum cross slope of the sidewalk shall be ¼-inch per foot. These sidewalks shall conform to the following standards:

- 1) Zoning Classification Requiring Sidewalks: Concrete sidewalks designed and located according to City standards shall be constructed along all streets in all zoning classifications except agricultural zoning. The Owner shall build sidewalks at the time of site development. Should it be impractical to install the sidewalk at that time, funds for the sidewalk construction shall be placed in escrow with the City for use at the time when sidewalks are needed. Payment or escrow shall be made at the time of site plan or final plat approval.
- 2) Residential Areas (Single Family, Two Family and Multi-Family): Sidewalks shall be 5-feet in width and located 1-foot from the back of the curb line or the edge of pavement and the adjacent property line. Along thoroughfares with inadequate right-of-way the sidewalk width shall be 5-feet in width and constructed adjacent to the back of curb.
- 3) Non-Residential Areas: Sidewalks shall be 5-feet in width and located at least 1-foot from the back of the curb line or the edge of pavement and the adjacent property line. Along thoroughfares with inadequate right-of-way the sidewalk width shall be 5-feet in width and constructed adjacent to the back of curb.
- 4) Exceptions: In areas where mailboxes and other structures interfere with a clear width of 5 feet for the sidewalk, the specified width shall be wrapped around and along one side of the mailbox or other structure.
- 5) Waiver: The sidewalk required in non-residential areas may be waived by the City Council either temporarily or permanently at the time of site plan or final plat approval. Waiver may be granted based on site conditions and/or location of the tract.

- 6) Areas Without Screening Walls: In areas on major and secondary roadways where either screening is not required or a type of screening other than a wall is used, (e.g., a berm, foliage, etc.) a 5-foot sidewalk will be constructed not more than 2½-feet from the back of the curb line or the edge of pavement and the adjacent property line as required by the Thoroughfare Plan.
- 7) Areas with Screening Walls: In areas where a screening wall is provided, a concrete sidewalk shall be constructed contiguous with the screening wall. The street side of the sidewalk shall run parallel to the street curb. The sidewalk shall be a minimum of 5-feet wide and the measurement shall be made from the street side of the sidewalk.
- 8) Sidewalk on Bridges: Bridges on thoroughfares shall have a sidewalk constructed on each side of the bridge. The sidewalk shall be a minimum of 6-feet wide with a parapet wall provided adjacent to the curb of the thoroughfare and with a standard pedestrian bridge rail protecting the sidewalk on the outside edge of the bridge.
- 9) Sidewalks Under Bridges: When new bridges are built as a part of the construction of a roadway or the reconstruction of a roadway and a pedestrian crossing is needed, an 8-foot sidewalk will be built as a part of the embankment design underneath the bridge structure. The 8-foot sidewalk shall be located generally along the toe of the embankment.

**B. BARRIER-FREE RAMPS (Compliance shall be with the American Disability Act)**

Curbs and walks constructed at intersections or all streets and thoroughfares must comply with the provisions of the American Disability Act and be constructed in a manner to be easily and safely negotiated by physically challenged persons.

## SECTION VII

### PUBLIC RIGHT-OF-WAY VISIBILITY

#### A. STREET/DRIVE INTERSECTION VISIBILITY OBSTRUCTION TRIANGLES-FRONTAGE PLAN/PROFILE

A landscape plan showing the plan/profile of the street on both sides of each proposed drive/street to the proposed development with the grades, curb elevations, proposed street/drive locations, and all Items (both natural and man-made) within the visibility triangles as prescribed below shall be provided with all site plans, if they are not on engineering plans that are submitted at the same time. This profile shall show no horizontal or vertical restrictions (either existing or future) within the areas defined below.

##### (1) Obstruction/Interference Triangles-Defined

No fence, wall, screen, billboard, sign, structure, foliage, hedge, tree, bush, shrub, berm, or any other item, either manmade or natural shall be erected, planted, or maintained in a position, which will obstruct or interfere with the following minimum standards.

- a) Vision at all intersections where streets intersect at or near right angles shall be clear at elevation between 2½-feet and 9-feet above the average gutter elevation, except single trunk trees, within a triangular area formed by extending the two curb lines from their point of intersection, 45-feet, and connecting these points with an imaginary line, thereby making a triangle. If there are no curbs existing, the triangular area shall be formed by extending the property lines from their point of intersection 30-feet and connecting these points with an imaginary line, thereby making a triangle. (see Detail, page 23)
- b) Definitions for desirable minimum sight distance requirements for non-residential streets, commercial driveways, and industrial driveways that intersect at or near right angles are presented below (see Detail, page 25). The values presented are minimum sight distances which would permit the following:

- T-Upon turning left or right, an exiting vehicle could accelerate to the operating speed of the street.

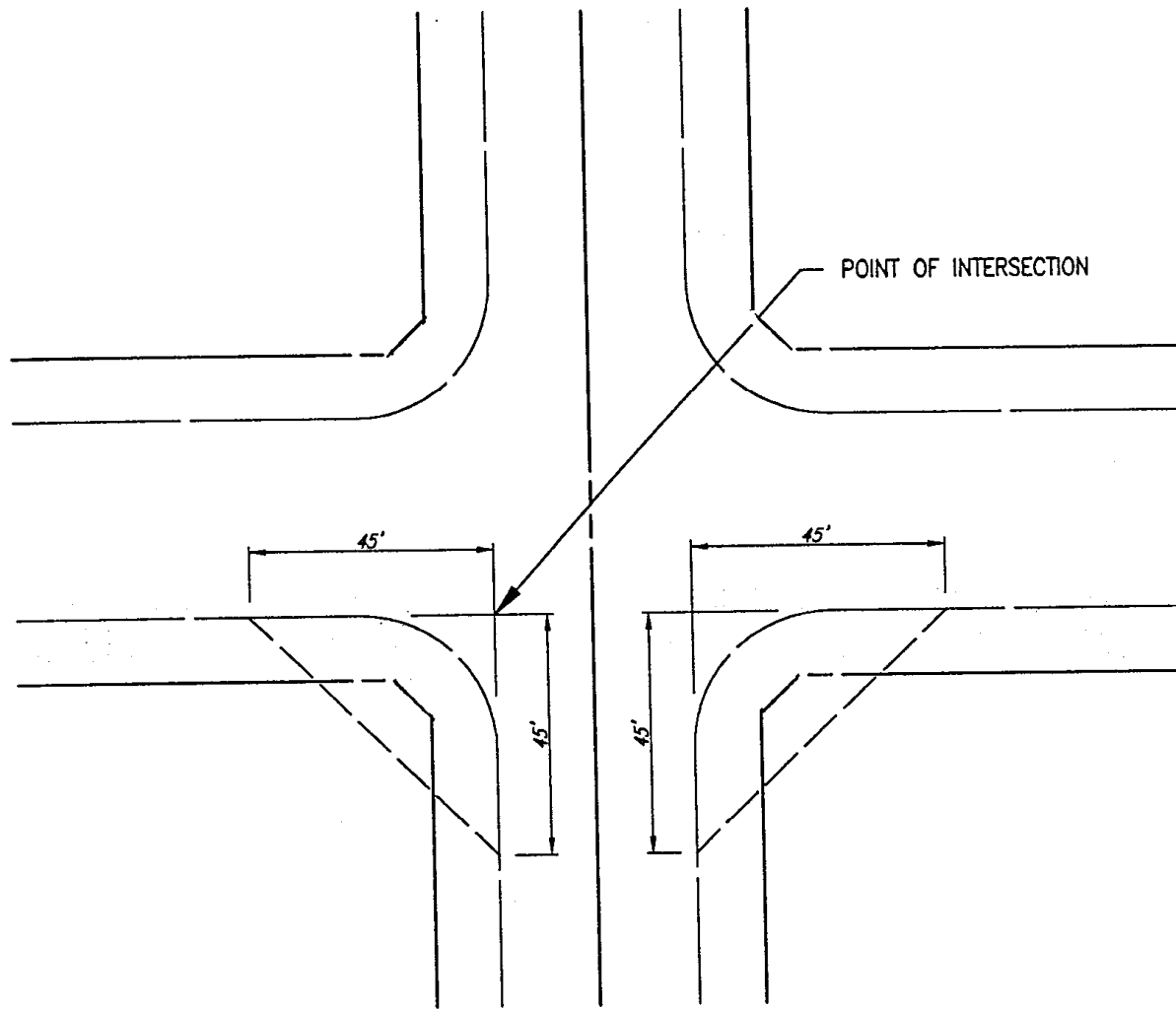

### HORIZONTAL CLEAR TRIANGLE

The desirable minimum sight distances are based on the premise that the approaching driver can observe the intersecting vehicle 2.5 seconds before he must apply the brakes and travel the minimum stopping distance for his approach speed. They are, therefore, particularly applicable to arterial streets. Actual sight distances provided at Intersections should be much greater than these minimum values if practical. The minimum sight distance triangle shall also apply to visibility obstructions at intersections.

Conditions for Intersection Sight Triangle-Plan/Profile:

- In the plan view, the horizontal clear area at the Intersection of a proposed street/drive shall be defined as being within a triangular area formed by:
  - (I) A line that is on the centerline of the proposed street/drive, beginning at the Intersecting street's tangent curb and continuing for a distance of 15-feet back into the proposed street/drive to the end point.
  - (II) A line that is parallel to and 5-feet out from the intersecting street's curb, beginning at the centerline of the proposed street/drive and continuing for a distance "T" as prescribed in Table 9, to the end point.
  - (III) A straight line that connects the end point of an:
    - That is on the centerline and 15-feet back into the proposed street/drive, and the end point of a
    - That is a distance "T" along and 5-feet out from the existing street's curb from the centerline or the proposed street/drive.

In the profile view, the clear window shall be defined as being within the horizontal clear area and clear between 2.5 feet and 9 feet above the average pavement elevation.

**Note:** Single trunk trees within the triangles and in the median shall be allowed and spaced so as to not cause a "picket fence" effect. Because of the large variation of ways in which trees can be planted, the spacing will be decided upon by the City Engineer and the developer at the time of review of the landscape plans. Any other item that obstructs these lines so as to interfere with the above requirements will not be allowed.



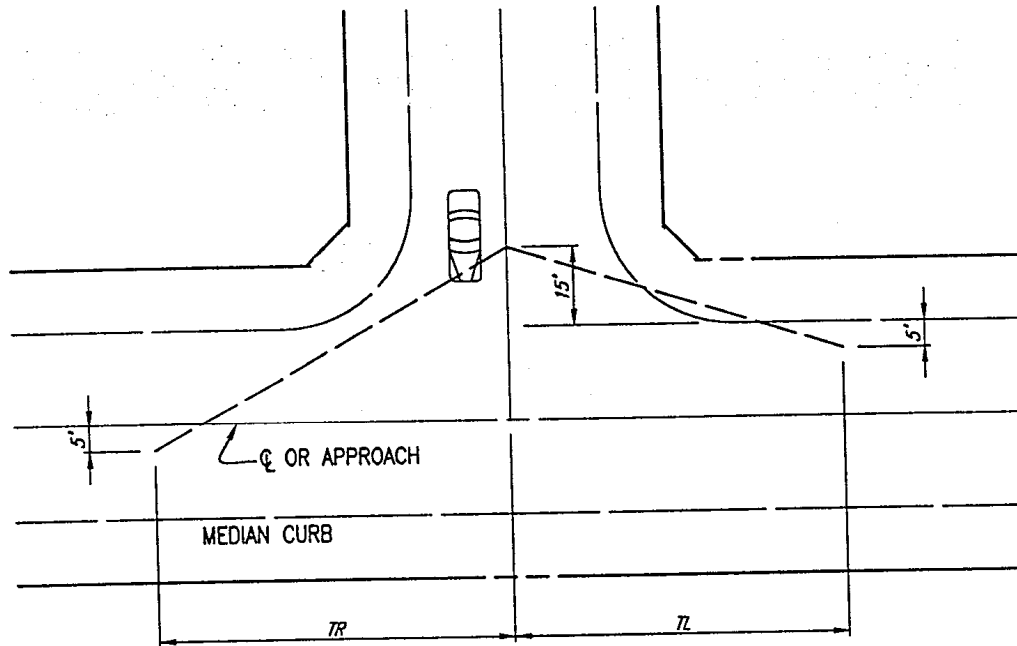

TABLE 9

MINIMUM SIGHT DISTANCE FOR  
A CAR AT AN INTERSECTION

<u>MPH</u>	<u>I</u>
30	110 + 200=310
35	130 + 250=380
40	130 + 325=475
45	165 + 400=565
50	190 + 475=665

(AASHTO P138, BRAKE REACTION DISTANCE  
+ STOPPING SITE DISTANCE)

**TABLE 9**  
**MINIMUM SIGHT DISTANCE FOR A CAR AT AN INTERSECTION**  
**(For Level-Two Lane Streets)**

MPH	T
30 .....	110 + 200 = 310
35 .....	130 + 250 = 380
40 .....	130 + 325 = 475
45 .....	165 + 400 = 565
50 .....	190 + 475 = 665

**AASHTO P138, Break Reaction Distance + Stopping Site Distance**

The aforementioned restrictions also apply to streets that do not intersect at right angles, except that the triangle dimensions shall not necessarily be minimum requirements. In such cases the City Engineer shall have the authority to vary such requirements as he deems necessary to provide safety for both vehicular anti pedestrian traffic.

**B. R.O.W. OBSTRUCTIONS OUTSIDE THE VISIBILITY TRIANGLES**

- 1) Foliage of hedges, trees and shrubs in public right-of-ways which are not governed by Zoning Ordinance of the City, or the above triangles shall be maintained such that the minimum overhung above a sidewalk shall be 7-feet, the minimum overhang above a street shall be 14-feet.
  
- 2) All other areas within the street right-of-ways shall be clear at elevations between 2½-feet and 9-feet above the average street grade,
  
- 3) Plants in the public right-of-way that will grow over 30-inches (when mature) above the adjacent street's curb will conform to all of the above requirements, where applicable. All landscape plans shall show the locations and type of such plants, and show each of the prescribed triangles.
  
- 4) Ground elevations, within both triangles, will be shown by contour lines.

**Note:** No plantings over 30-inches above the adjacent gutter elevation are allowed In the median for the length of the left turn stacking space unless specifically agreed upon by the City Engineer.

**C. ALLEY VISIBILITY OBSTRUCTIONS**

No fence, wall, screen, billboard, sign, structure, or foliage of hedges, trees, bushes, or shrubs shall be erected, planted or maintained in any alley right-of-way. Foliage or hedges, trees, bushes, and shrubs planted adjacent to the alleys right-of-way which are not governed by the above triangles or by Zoning Ordinance of the City, shall be maintained such that the minimum overhang or encroachment shall be 14-feet above the alley surface at the edge of the pavement.

**D. EXCEPTIONS**

The provisions of this manual shall not apply to, or otherwise interfere with, the following:

- 1) Placement and maintenance of traffic control devices under governmental authority and control.
- 2) Existing and future screening requirements Imposed by the City Council.
- 3) Existing and future City, State and Federal Regulations.

## **SECTION VIII**

### **OFF STREET REQUIREMENTS**

#### **A. STACKING SPACE FOR DRIVE-UP WINDOWS**

The minimum stacking space for the first vehicle stop for a commercial drive-through shall be 100-feet, and 40-feet thereafter, for any other stops.

#### **B. PARKING - LOT LAYOUT**

- 1) All parking lots shall be paved with concrete unless otherwise approved by City Council.
- 2) No parking area will be allowed to dead-end unless adequate turnaround space is proved.
- 3) Each standard off-street parking space shall contain not less than 162 square feet and measure not less than 9 feet by 18 feet, exclusive of access drives and aisles, and shall be of usable shape and condition.
- 4) The width for two-way aisles shall be a minimum of 24-feet and a maximum of 45-feet.
- 5) Handicapped parking spaces shall be a minimum 10-feet in width with a 5-foot minimum walkway. The walkway can be shared by two spaces. For parallel parking the space shall be a minimum of 24-feet by a minimum 13-feet with a 3-foot minimum walkway one end in addition to the minimum 24-foot dimension. (see Detail, page 29)
- 6) Parking Overhang: No parking stall shall be situated so as to allow vehicle overhand into public right-of-way. Curb or parking stops shall be installed so that the distance between the face of the curb or car stop is a minimum of 2-feet from the public right-of-way.
- 7) Movements in Public Right-of-Way: No parking stall shall be so designed as to allow any movement into or out of the stall, upon public right-of-way.
- 8) Parking lot illumination shall be designed and constructed to direct the light to the parking lot and away from any adjoining property or street.
- 9) Fire lanes shall be constructed as required by Fire Department rules and regulations.

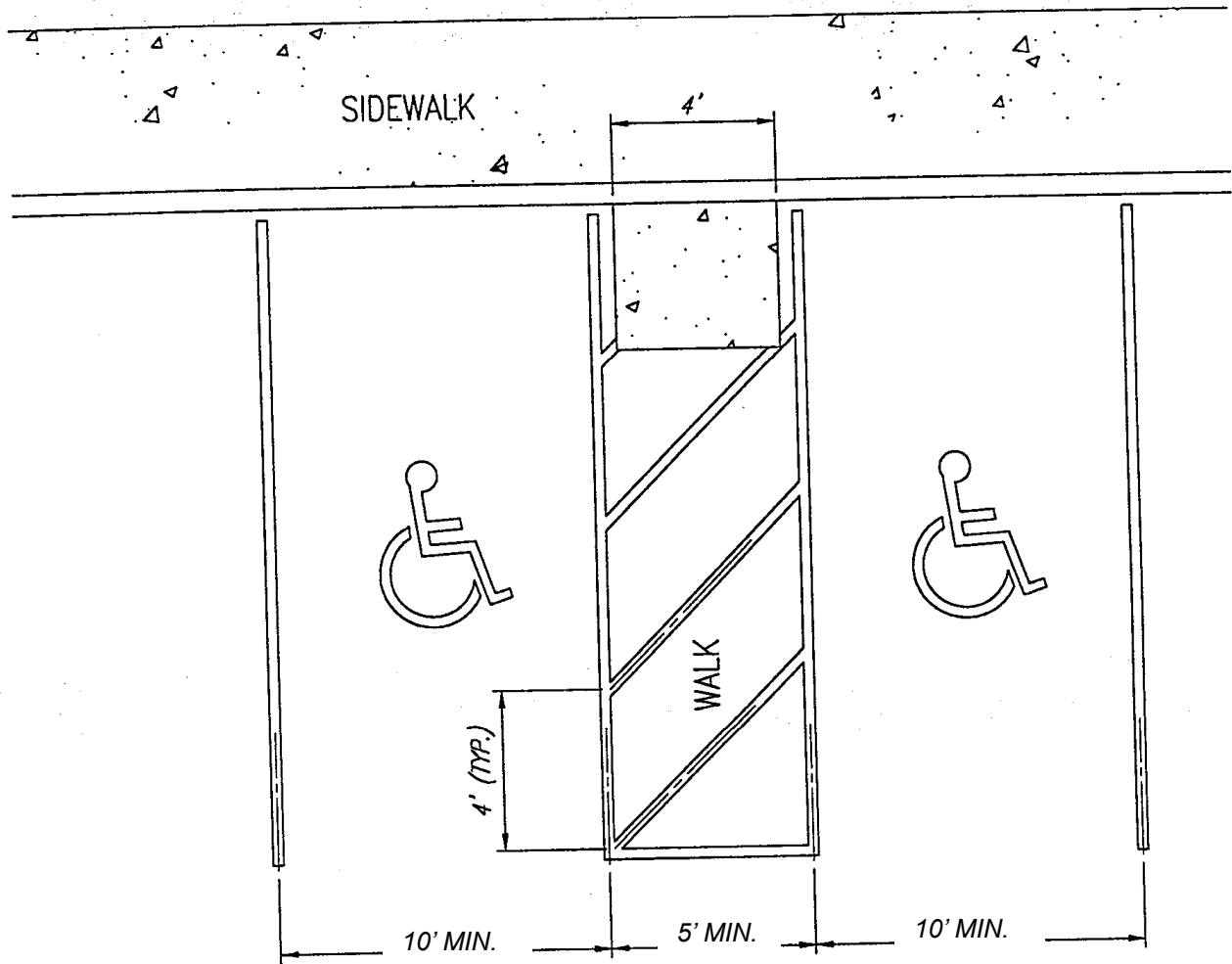

## HEAD-IN OR ANGLE PARKING DIMENSIONS

**SECTION IX**  
**RURAL SUBDIVISION REQUIREMENTS**

**A. Construction and Improvement Specifications for Rural Subdivisions**

- A.1 Driveways in a rural subdivision shall be constructed with six inches (6") of 3,000 p.s.i. concrete, reinforced with #4 rebar on twenty-four inch (24") centers.
- A.2 Driveway approaches in a rural subdivision shall allow for a twelve foot (12') shoulder extension to the county road (see specifications to improvements to county roads), shall be a minimum of thirty feet (30') long, shall provide a minimum eighteen inch (18") reinforced concrete culvert, with 6 to 1 safety end treatments, and shall provide a minimum of six inches (6") flex base material for approach subgrade (flex base material type A grade 1 TXDOT standard).
- A.3 If the existing county road has less than an asphalt surface, the developer shall improve the road as follows; minimum three inches (3") of asphalt base course Type B Tex. D.O. T. standard with two inches (2") of surface course asphalt Type B Tex. D.O.T standard, allowing for future shoulder improvement.
- A.4 A rural subdivision shall have a minimum county road frontage of one-hundred twenty-five feet (125').
- A.5 Prior to development of the interior of a rural subdivision, the existing asphalt county road shall be improved as follows:
- (1) A twelve foot (12') shoulder must be added, to the following specification; a six inch (6") stabilized sub base with a minimum 6% by dry weight of lime (27 pounds per square yard for 6" of depth); a minimum of twelve inches (12") flex base material Type A grade 1 TXDOT standard; minimum three inches (3") asphalt base coarse Type B TXDOT. Standard; and
  - (2) Overlay both sections, shoulder and existing road, with two inches (2") surface course asphalt Type B Tex. D.O.T. standard

A.6 A rural subdivision shall provide right-of-way as provided in the subdivision ordinance, according to street type.